

JORDON

AUTOMATIC ICE MAKER Use and Care Guide

Parts and features

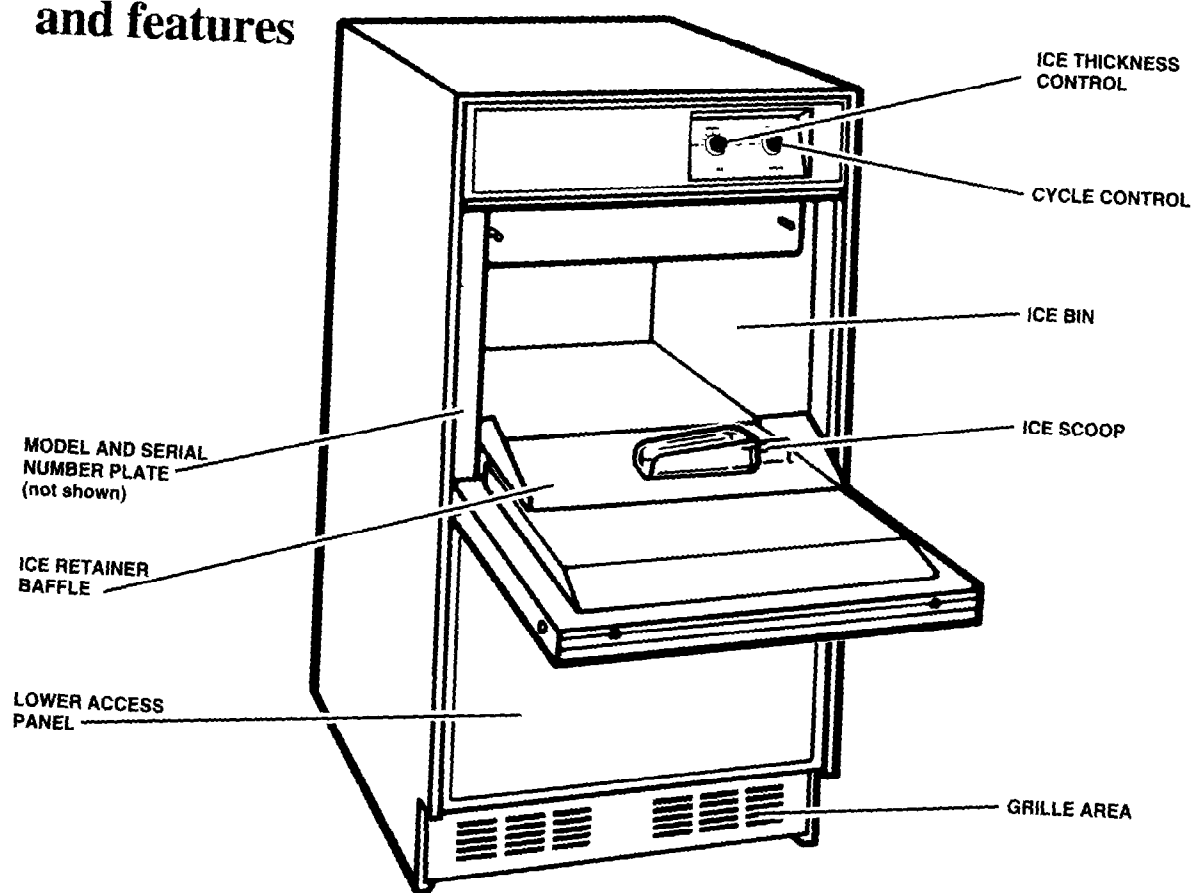

Copy your Model and Serial Numbers here ...

When you need service, or call with a question, have this information ready.

1. **Complete** Model and Serial Numbers (from the plate located as shown).
2. Purchase date from sales slip.

Copy this information in these spaces. Keep this book, your warranty, and sales slip together in a handy place.

Model Number	_____
Serial Number	_____
Purchase Date	_____
Service Company and Telephone Number	_____

Part No. 2180622

1/94

Contents

	Page	Page	
BEFORE YOU PLUG IT IN	2	Cleaning Exterior Surfaces	5
USING YOUR ICE MAKER	2	Cleaning the Condenser	5
How the Ice Maker Works	2	Cleaning the Ice Maker System	6
Setting the Controls	3	Cleaning the Interior Components	7
Changing the Bin Door Panel	3	Filtering and Treating Water	8
Changing the Lower Access Panel	4	VACATION AND MOVING CARE	8
CLEANING AND CARING FOR YOUR ICE MAKER	5	IF YOU NEED SERVICE OR ASSISTANCE	12
		Before Calling for Service	12

Before you plug it in

IMPORTANT

Before using your ice maker, you are responsible for making sure that it ...

- has been installed where it is protected from the elements.
- is located so that the front is not blocked to restrict incoming or discharge airflow.
- is properly leveled.
- is located in a well-ventilated area with temperatures above 55°F (13°C) and below 110°F (43°C). Best results are obtained at temperatures between 70°F (21°C) and 90°F (32°C).
- is properly connected to a water supply and drain.
- is properly connected to electricity. A 115 Volt, 60 Hz., AC only, 15 or 20 ampere electrical supply circuit, properly grounded in accordance with the National Electrical Code and local codes and ordinances, is required. **NOTE:** A time delay fuse or circuit breaker is recommended.
- is not operated by anyone unable to use it properly.
- is used only for the job it was designed to perform.
- is properly maintained.

Using your ice maker

How the ice maker works

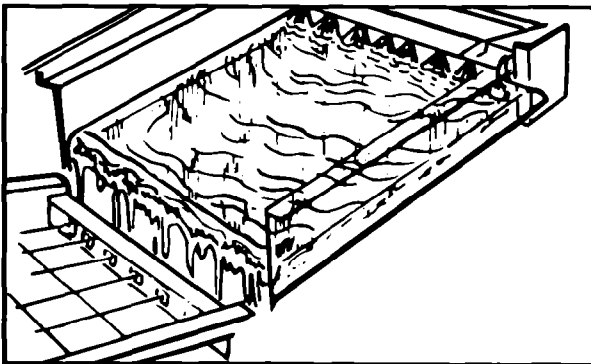

1. Water is constantly circulated over a freezing plate. As the water freezes into ice, the minerals in the water are rejected. This produces a clear sheet of ice with a low mineral content.

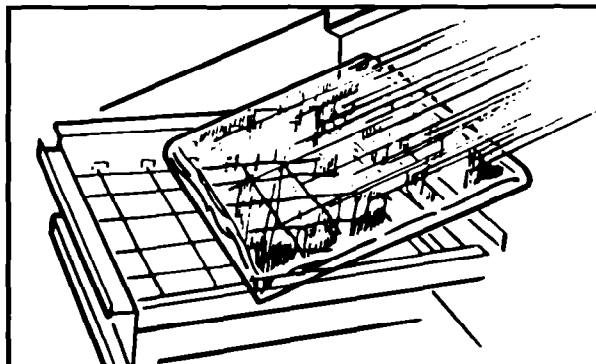

2. When the desired thickness is reached, the ice sheet is released and slides onto a cutter grid. The grid divides the sheet into individual cubes.

3. The water containing the rejected minerals is drained after each freezing cycle.
4. Fresh water enters the machine for the next freezing cycle.
5. Cubes fall into the storage bin. When the bin is full, the ice maker shuts off automatically and restarts when more ice is needed.

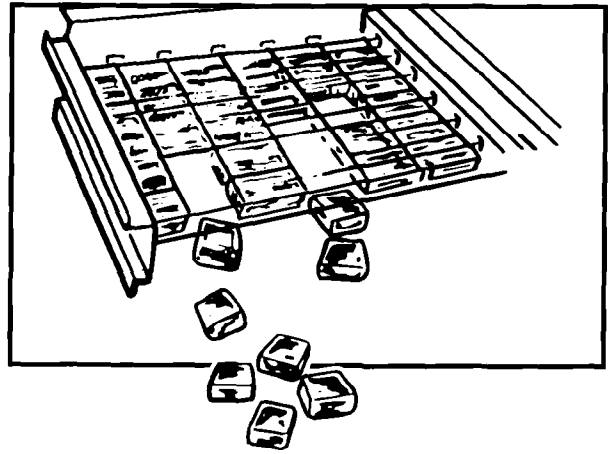

Setting the controls

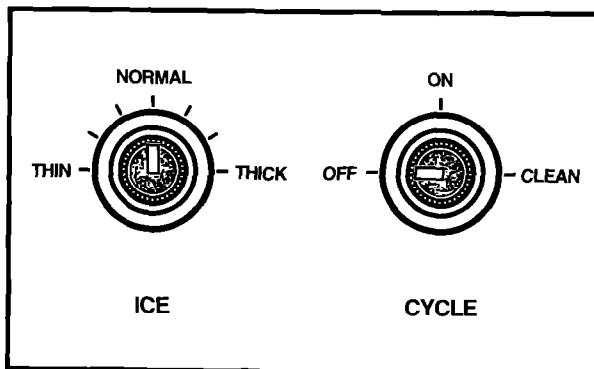

1. Select an ice thickness. The ice maker has been preset to produce ice approximately 1/2" thick while operating in a room temperature of 70°F (21°C).

Operation in different room temperatures may require readjusting the Ice Thickness Control Knob toward "THICK" or "THIN."

Best operation will be obtained with Ice 1/2" to 5/8" thick.

If operating in a warm room temperature (above 90°F (32°C)), **DO NOT** set Ice Thickness Control Knob to maximum thickness. Doing so could cause the unit to malfunction.

2. To start the normal freezing cycle, turn the Cycle Control Knob to "ON."
3. To stop ice maker operation, turn the Cycle Control Knob to "OFF."

The "CLEAN" setting is used whenever solutions are circulated through the ice maker for cleaning. Only the water pump operates at this setting.

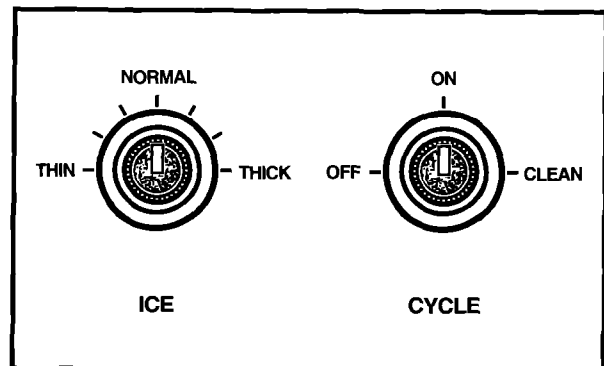

Changing the bin door panel

You can make a decorative wood front to match existing cabinets.

To change the bin door panel:

1. Open the storage bin door. Remove the two screws holding the handle to the door frame.
2. Loosen the screws in both side trim pieces.
3. Remove the handle.

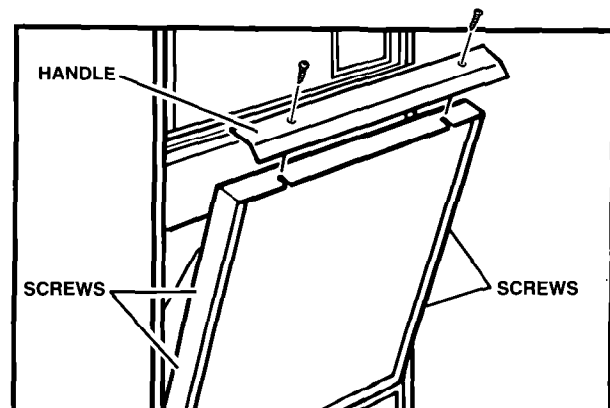

4. Carefully slide the panel out and break off the ribs on the door insulation to allow room for the wood panel's thickness.
5. Make the wood panel $\frac{1}{4}$ " (6 mm) thick and $17" \times 13\frac{3}{8}"$ (433 mm x 335 mm).
6. Replace the handle and tighten the screws in both side trim pieces. Replace the handle screws and tighten.

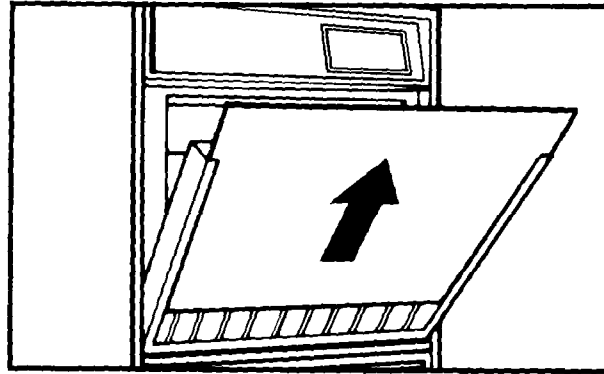

Changing the lower access panel

⚠ WARNING

Electrical Shock Hazard

Do not operate the ice maker with the lower access panel or control panel removed. Electrical shock or personal injury could result.

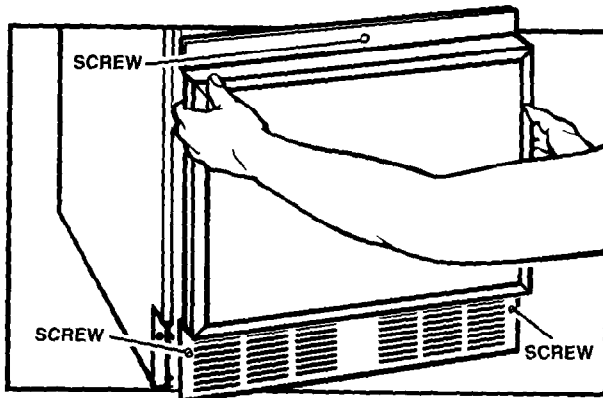

1. Remove the two screws in the lower grille area and the one screw from the center of the front panel support. (Open bin door slightly for better access to screw.) Pull forward and down to remove the lower access panel.

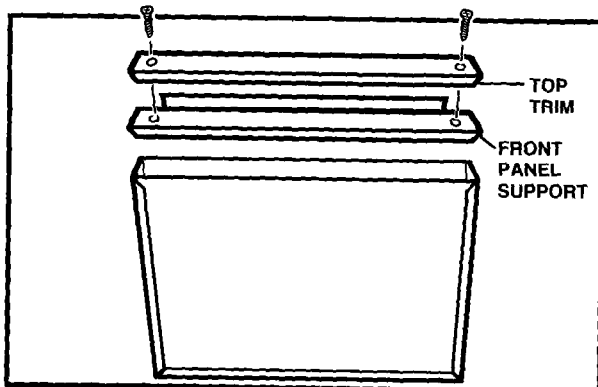

2. Remove the two screws from the top panel trim. Then remove the top trim and front panel support.

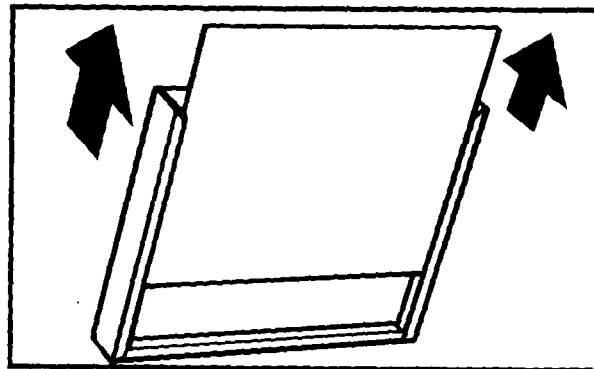

3. Carefully slide the metal panels and spacers out.
4. Make a decorative wood front to match your existing cabinets. The panel should be $\frac{1}{4}$ " (6 mm) thick and $17" \times 11\frac{5}{8}"$ (433 mm x 303 mm).
5. Slide in wood front. Replace the front panel support, top trim, and screws. Replace the lower access panel and screws.

Cleaning and caring for your ice maker

Periodically inspect and clean the ice maker to keep it operating at peak efficiency and to prevent premature failure of system components.

Both the ice making system and the air-cooled condenser need to be cleaned regularly.

The minerals rejected from the circulating water during the freezing cycle will eventually form a hard, scaly deposit in the water system which prevents a rapid release of the ice from the freezing plate.

Clean the ice and water systems periodically to remove mineral scale buildup. Frequency of cleaning depends on water hardness. With water that contains few impurities, cleaning may not be required for several years. With hard water (15 to 20 grains/gallon), cleaning may be required as frequently as every six months.

A dirty or clogged condenser:

- prevents proper airflow.
- reduces ice making capacity.
- causes higher than recommended operating temperatures which may lead to component failure.

Cleaning exterior surfaces

Wash the exterior painted surfaces and gaskets with warm water and mild soap or detergent. Rinse and dry. Regular use of a good household appliance cleaner and wax will help protect the finish.

Do not use harsh or abrasive cleaners on the enamel surfaces. They may scratch the finish.

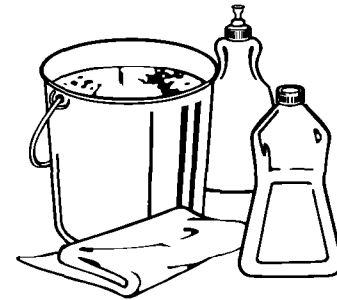

Cleaning the condenser

⚠️ WARNING

Personal Injury and Product Damage Hazard

- Be sure the ice maker is **OFF** and disconnected from the main power supply. Condenser fan rotation, sharp condenser fins, and hot tubing could cause personal injury.
- Condenser fins can bend easily. Use care when vacuuming the condenser to keep from bending fins. Product damage could result.

1. Turn the Cycle Control Knob to the "OFF" position. Then disconnect electrical supply to the ice maker.

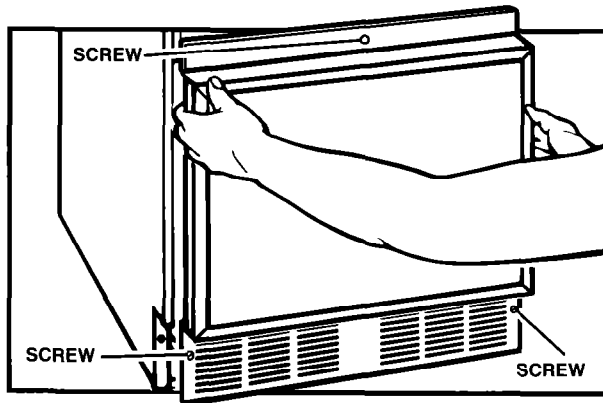

2. Remove the two screws in the lower grille area and the one screw from the center of the front panel support. (Open bin door slightly for better access to screw.)
3. Pull forward and down to remove the lower access panel.

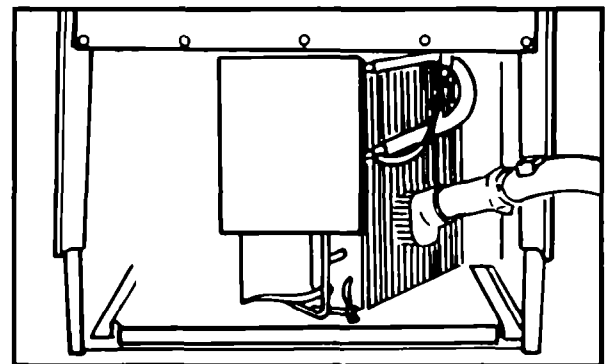

4. Remove dirt and lint from the condenser fins and the unit compartment with a brush attachment connected to a vacuum cleaner.
5. Replace the lower access panel and screws.
6. Plug ice maker in and place the Cycle Control Knob in the "ON" position.

Cleaning the ice maker system

⚠ WARNING

Personal Injury Hazard

Most ice machine cleaners are citric or phosphoric acid which can cause irritation, even after dilution. In case of contact with eyes, flush eyes thoroughly with fresh water and contact a physician immediately. In case of contact with skin, rinse well with water. If *swallowed*, give large amounts of water and contact a physician immediately. Do not induce vomiting. **KEEP OUT OF THE REACH OF CHILDREN.**

1. Place the Cycle Control Knob in the "OFF" position.

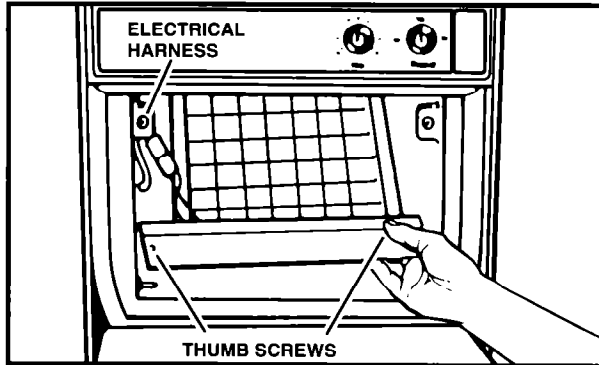

2. Remove the two thumb screws, and slide the ice cutter grid forward, out of the two slots near the water pan.
3. Unplug the electrical harness.

⚠ CAUTION

Any ice on the grid should be melted under running warm water. Attempting to pick the ice slab from the grid may stretch and damage the grid wires.

4. Remove all ice from the storage bin and the freezing place.

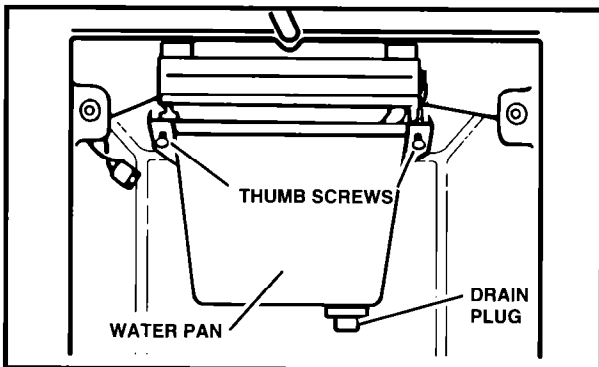

5. Drain the water pan by removing the drain plug. When finished, replace the drain plug.

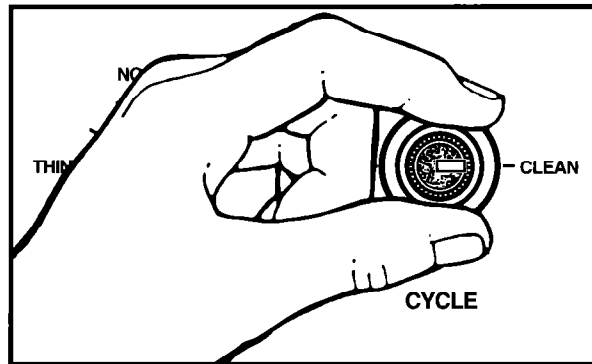

6. Pour 2 quarts (2 L) of hot water into the water pan and turn the cycle control to "CLEAN." This step warms up the system and allows the cleaning solution to be more effective. Allow to circulate 5 minutes. Turn switch to "OFF" and drain. Prepare the cleaning solution by thoroughly mixing 6 oz. (170 g) of powdered citric acid or phosphoric acid into 2 quarts (2 L) of hot water. Commercial ice machine cleaners are also available in liquid form and should be mixed according to instructions on the label.
7. Pour cleaning solution into water pan and turn switch to "CLEAN." If solution foams while pouring, stop until foaming subsides, then add balance of solution. Allow solution to circulate until scale has dissolved. The circulating solution may not contact scale on the side flanges of the freezing plate. To remove this scale, wear rubber gloves and use a stainless steel sponge or pad dipped in cleaning solution to scrub the side flanges until scale is removed. Generally scale will be dissolved in 15 to 30 minutes. Severe scale formation may require repeating the cleaning process with a fresh quantity of solution if the scale has not dissolved after 30 minutes.
8. Turn switch to "OFF" and drain.
9. Follow cleaning with two fresh water rinses, circulating each rinse for 5 minutes, and drain.
10. This completes the "in place" cleaning and sanitizing of the water system and freezing plate. Other interior components must also be cleaned and sanitized.

Cleaning the interior components

⚠ WARNING

Personal Injury Hazard

Do not operate the ice maker with the lower access panel, lower grille area, or control panel removed. Personal injury could result.

1. Turn the Cycle Control Knob to "OFF," and disconnect the electrical power supply to the ice maker. Open the storage bin door and remove any ice that is in the bin.

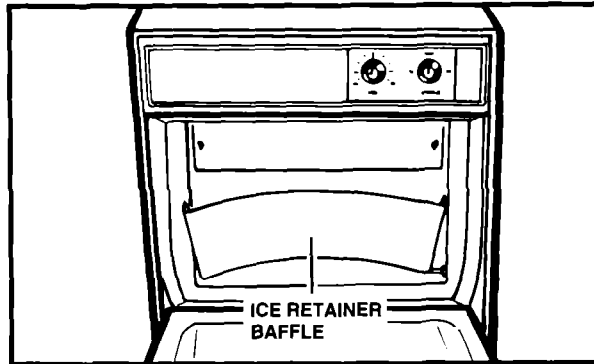

2. Remove the ice retainer baffle by flexing it and sliding it off the studs.
3. Remove the ice cutter grid by unscrewing the two thumb screws, sliding the grid forward, and unplugging the electrical wire harness.

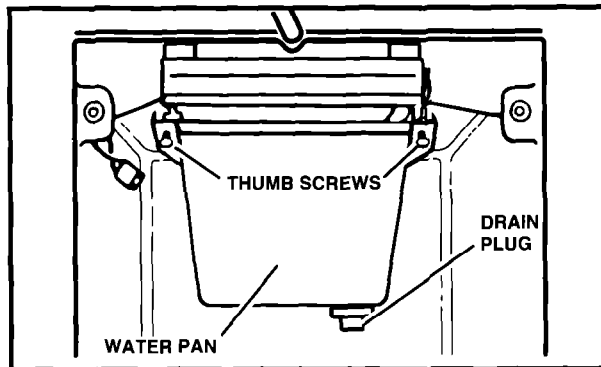

4. Remove the water pan by unscrewing the two thumb screws.

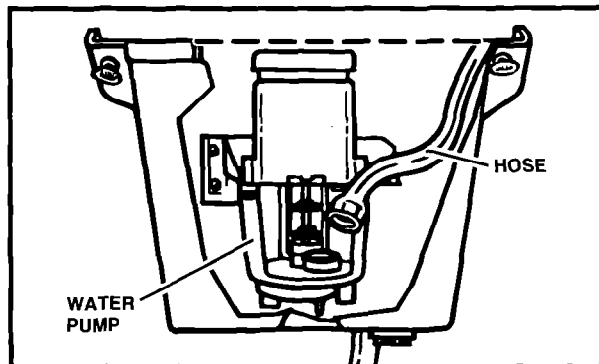

5. Remove the hose from the water pump.

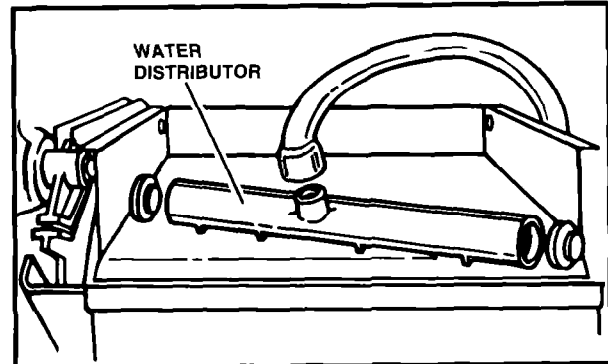

6. Remove the water distributor from the freezing plate. It is held in place by rubber end caps. Remove the inlet hose and clean all water distributor holes and the small orifice in the inlet side of the distributor. When replacing the distributor, make sure the end caps are located in the evaporator flange detents and that the water distributor holes face down.
7. Wash the **interior components** (ice retainer baffle, cutter grid, water pan, inlet hose, and water distributor) and the storage bin, door gasket, and ice scoop with mild soap or detergent and warm water. Rinse in clean water. The components should also be cleaned in a solution of $\frac{1}{4}$ oz. (8 mL) of chlorine bleach mixed with 1 gallon (3.8 L) warm water.
DO NOT WASH PLASTIC PARTS IN THE DISHWASHER. They cannot withstand temperatures above 145°F (63°C).
8. Replace the interior components (water distributor, inlet hose, water pan, cutter grid, and ice retainer baffle).
9. Check the following:
 - Hose from water valve is in the water pan.
 - Rubber drain plug is in the water pan.
 - Water distributor is seated and holes are facing down.
 - Hose is reconnected to the pump and the water distributor.
 - Hose from water pan is inserted into the storage bin drain opening.

Reconnect the electrical harness, and slide cutter grid into place. Tighten the thumb screws.

Filtering and treating water

In some areas, it may be beneficial to filter or treat the water being supplied to the ice machine. It can improve the reliability of the machine, reduce water system maintenance, and produce a better quality of ice.

The installation of a polyphosphate feeder will generally reduce scale buildup, and the ice machine will require less frequent cleaning.

For information about filtering and treating the water, see the dealer from whom you purchased your ice machine.

Vacation and moving care

To shut down the ice maker:

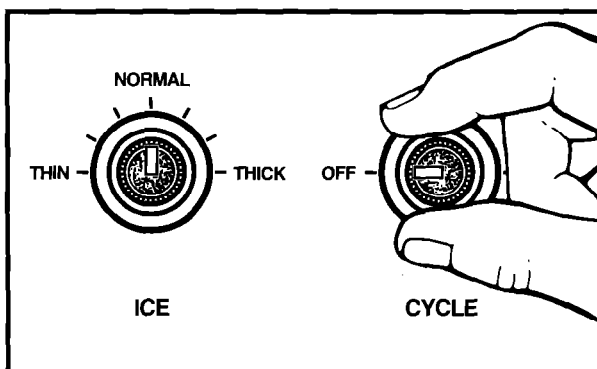

1. Turn the Cycle Control Knob to "OFF."
2. Remove all ice from the storage bin.
3. Shut off the water supply.

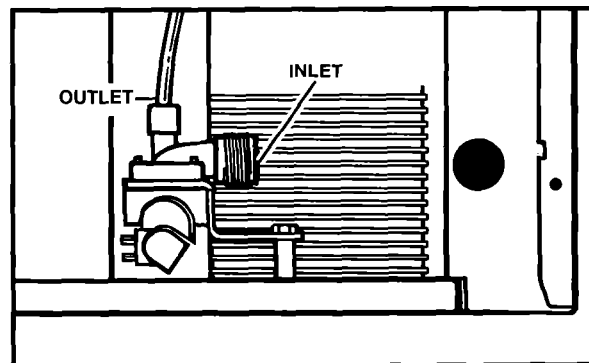

5. Disconnect the inlet and outlet hoses to the water valve. Allow these hoses to drain, then reconnect them to the valve.
6. Replace the lower access panel and screws.

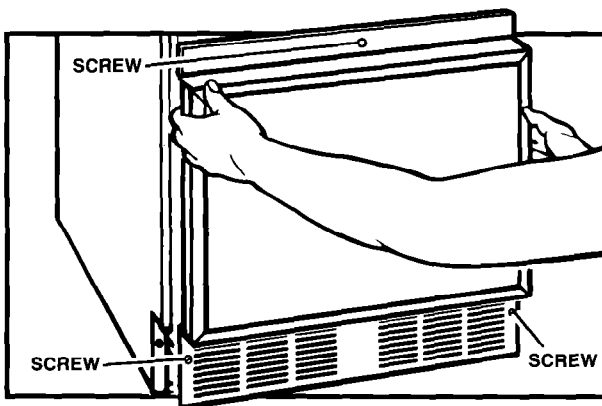

4. Remove the two screws in the lower grille area and the one screw from the center of the front panel support. (Open bin door slightly for better access to screw.) Pull forward and down to remove the lower access panel.

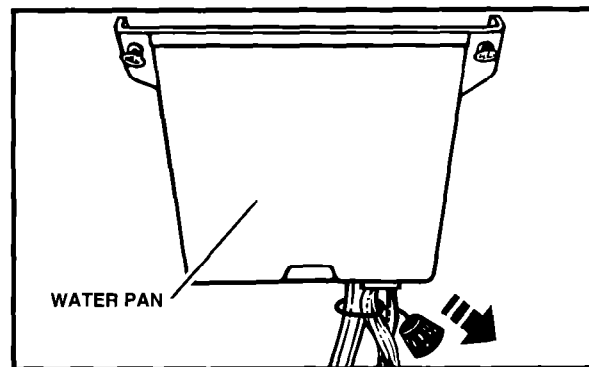

7. Remove water from the drain lines and drain the water pan.
8. Before using the machine again, clean the ice maker system, interior components, and the storage bin.

NOTE: All components of the ice machine are permanently lubricated at the factory. They should not require any additional oiling throughout the normal life of the machine.

If you need service or assistance, we suggest you follow these steps:

Before calling for service ...

Performance problems often result from little things you can find and fix yourself, without tools of any kind.

Unit does not run:

- Cycle Control Knob must be in the "ON" position.
- Check to see that the power cord is plugged in.
- Check for a blown fuse or tripped circuit breaker in the electrical supply to the machine.
- Room temperatures must be above 55°F (13°C). Otherwise, the Bin Thermostat may sense a cold room temperature and shut off even though the storage bin is not full of ice. Also, the unit may not restart once it does shut off.

Unit runs but does not produce ice:

- Cycle Control Knob must be in the "ON" position.
- Check water supply to make sure it is open.
- If ice machine is operated at an elevation above 2000 feet above sea level, both the Bin Thermostat and the Ice Thickness Thermostat need to be recalibrated. See Installation Instructions.

Unit runs but produces very little ice:

- Room temperature may be extremely high (over 90°F (32°C)). In this case, it is normal for ice production to be low.
- Dirt or lint may be blocking the airflow through the finned condenser. Condenser needs to be cleaned.
- Check to see if the unit has a scale buildup in the water and/or freezing systems. Clean them, if necessary.

Grid is not cutting ice sheets:

- Check the grid harness plug to make sure the connection is secure.

Off taste in ice cubes:

- There may be an unusually high mineral content in the water supply. Water may need to be filtered or treated.
- Do not store any foods in the ice bin.
- Packaging materials are not all removed.